



Please write clearly in block capitals.

Centre number

--	--	--	--	--

Candidate number

--	--	--	--

Surname

Forename(s)

Candidate signature

I declare this is my own work.

GCSE BIOLOGY

H

Higher Tier Paper 2H

Friday 7 June 2024

Afternoon

Time allowed: 1 hour 45 minutes

Materials

For this paper you must have:

- a ruler
- a scientific calculator.

Instructions

- Use black ink or black ball-point pen.
- Pencil should only be used for drawing.
- Fill in the boxes at the top of this page.
- Answer **all** questions in the spaces provided.
- If you need extra space for your answer(s), use the lined pages at the end of this book. Write the question number against your answer(s).
- Do all rough work in this book. Cross through any work you do not want to be marked.
- In all calculations, show clearly how you work out your answer.

Information

- The maximum mark for this paper is 100.
- The marks for questions are shown in brackets.
- You are expected to use a calculator where appropriate.
- You are reminded of the need for good English and clear presentation in your answers.

For Examiner's Use	
Question	Mark
1	
2	
3	
4	
5	
6	
7	
8	
9	
TOTAL	



J U N 2 4 8 4 6 1 2 H 0 1

Answer **all** questions in the spaces provided.

0 1

Evolution of new species occurs by mutation and natural selection.

0 1 . 1

What is a mutation?

[1 mark]

0 1 . 2

Describe the process of natural selection.

[3 marks]

0 1 . 3

Which scientists suggested the theory of evolution by natural selection?

[1 mark]

Tick (✓) **one** box.

Alexander Fleming and Carl Woese

Alfred Wallace and Alexander Fleming

Alfred Wallace and Charles Darwin

Charles Darwin and Carl Woese



0 1 . 4

The hoverfly and the wasp are insects with bright yellow and black markings.

Figure 1 shows a hoverfly and a wasp.

Figure 1

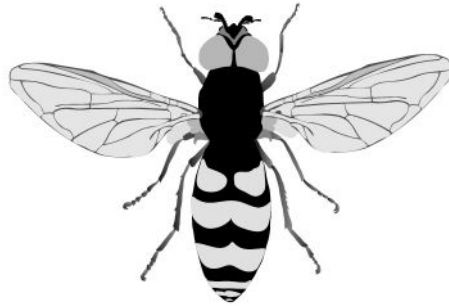

Hoverfly



Wasp

The wasp has a sting to defend itself against predators.

The hoverfly does **not** have a sting.

Hoverflies and wasps live in the same habitat.

Explain how having yellow and black markings helps the **hoverfly** survive.

[3 marks]

8

Turn over for the next question

Turn over ►



0 2

Peat bogs are estimated to contain twice as much carbon as all the world's forests.

Figure 2 shows a section through part of a peat bog.

Figure 2

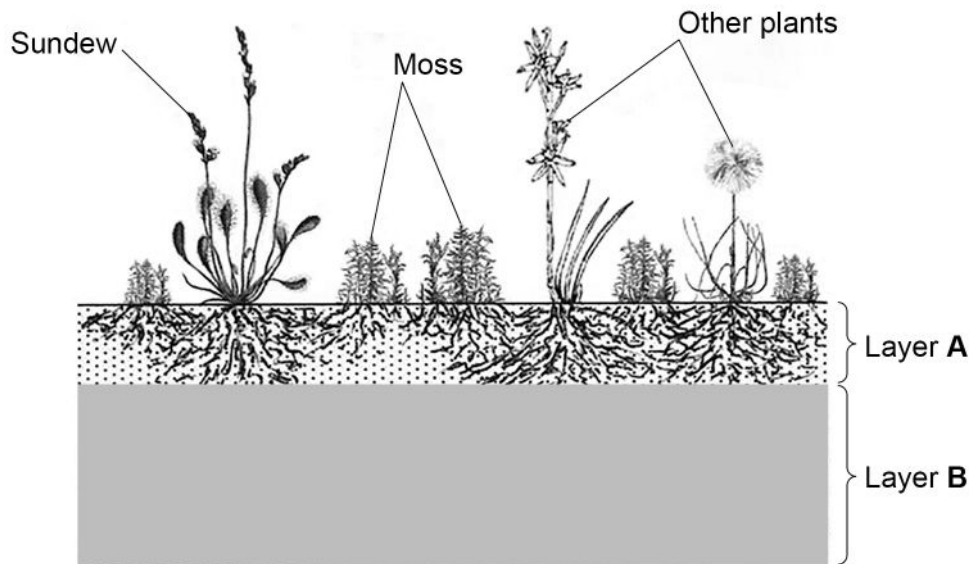

Layer **A** contains a lot of air.

Layer **B**:

- contains the dead remains of plants
- has a low pH
- contains very little oxygen
- contains carbon dioxide and methane.



0 2 . 1

Explain why most of the dead remains of plants in layer **B** do **not** decay.

[3 marks]

0 2 . 2

The peat bog in **Figure 2** is a stable community.

The moss produces biomass at a rate of $340 \text{ g/m}^2/\text{year}$.

What is the approximate biomass of the moss that becomes biomass in primary consumers?

[1 mark]

Tick (✓) **one** box.

$0.34 \text{ g/m}^2/\text{year}$

$3.4 \text{ g/m}^2/\text{year}$

$34 \text{ g/m}^2/\text{year}$

$340 \text{ g/m}^2/\text{year}$

Question 2 continues on the next page

Turn over ►

The sundew plant shown in **Figure 2** on page 4 has leaves with sticky hairs that trap and digest insects.

Digestion of the insects releases phosphates and simple compounds of nitrogen that are used by the sundew plant.

0 2 . 3 What substance can the sundew plant make using the **phosphates**?

[1 mark]

Tick (✓) **one** box.

Cellulose

DNA

Glycerol

Starch

0 2 . 4 What substance can the sundew plant make using the **nitrogen**?

[1 mark]

Tick (✓) **one** box.

Fatty acid

Glucose

Lactic acid

Protein



0 2 . 5

Humans have destroyed large areas of peat bog to collect peat.

The peat provides fuel and provides compost for gardeners to use.

The peat comes from layer **B** in **Figure 2** on page 4.

Layer **B**:

- contains the dead remains of plants
- has a low pH
- contains very little oxygen
- contains carbon dioxide and methane.

Figure 3 shows the removal of peat from a peat bog.

Figure 3

Peat is dug out and cut into 'bricks' that are left to dry



Explain how the destruction of peat bogs and the use of peat affects the temperature of the Earth's atmosphere.

[4 marks]

10

Turn over ►



Turn over for the next question

*Do not write
outside the
box*

**DO NOT WRITE ON THIS PAGE
ANSWER IN THE SPACES PROVIDED**



0 3

Frogs are animals that lay their eggs in water. The eggs hatch as tadpoles.

Students investigated the number of tadpoles in a pond for 8 weeks.

This is the method used.

1. Collect 10 dm³ of pond water in a bucket.
2. Count the number of tadpoles collected.
3. Put the tadpoles back into the pond.
4. Repeat steps 1 to 3 another three times in different parts of the pond.
5. Repeat steps 1 to 4 at intervals for 8 weeks.

0 3 . 1

Suggest **one** improvement to the method.

[1 mark]

Question 3 continues on the next page

Turn over ►

Table 1 shows the results.

Table 1

Sample number	Number of tadpoles in each sample					
	0 weeks	1 week	2 weeks	3 weeks	5 weeks	8 weeks
1	11	17	8	9	5	0
2	15	11	12	7	0	5
3	23	16	14	10	7	3
4	11	14	16	X	4	4
Totals	60	58	50	32	16	12

0 3 . 2 Value **X** is the number of tadpoles in sample 4, at 3 weeks.

Calculate value **X**.

[1 mark]

Value **X** = _____



0 3 . 3

Complete **Figure 4** to show how the **total** number of tadpoles changed over the 8 weeks.

[4 marks]

You should:

- label the x-axis
- use a suitable scale for the x-axis
- plot the data for the **total** numbers of tadpoles from **Table 1**
- draw a line of best fit.

Figure 4

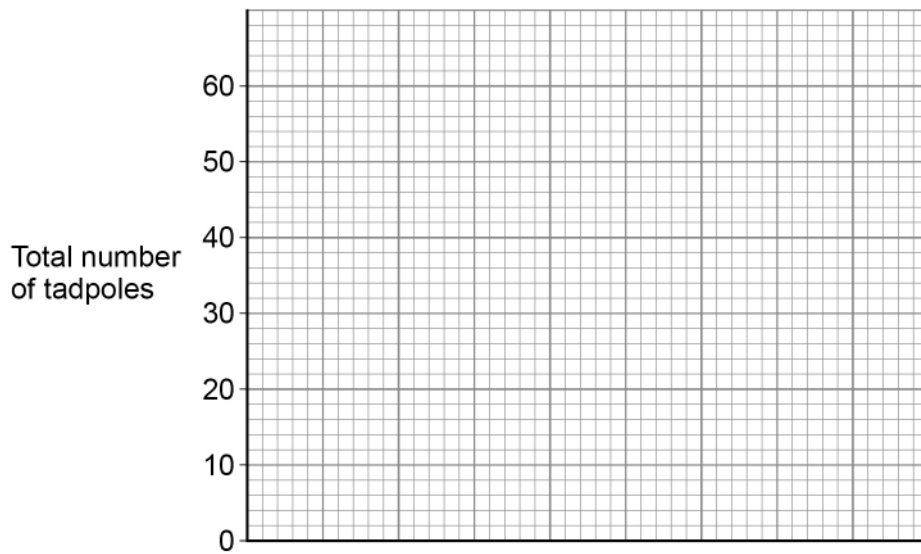

0 3 . 4

After 0 weeks, no more tadpoles hatched in the pond.

Calculate the percentage of the tadpoles that would still be found in the pond at 4 weeks compared with 0 weeks.

Use information from **Figure 4**.

[3 marks]

Percentage of tadpoles found at 4 weeks = _____ %

Turn over ►



0 3 . 5 After 4 weeks many of the tadpoles had died.

Suggest **two** reasons why the tadpoles died.

[2 marks]

1 _____

2 _____

11



Turn over for the next question

*Do not write
outside the
box*

**DO NOT WRITE ON THIS PAGE
ANSWER IN THE SPACES PROVIDED**

Turn over ►



0 4

A student investigated the effect of gravity on the growth of bean seedlings.

The student put ink marks on the root of each bean seedling.

Figure 5 shows a bean seedling with ink marks.

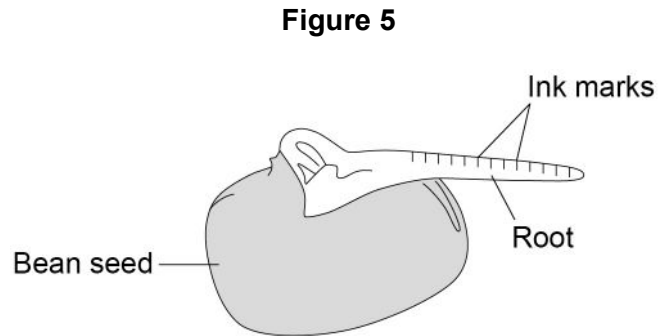

The student set up apparatus **A** and apparatus **B**.

Figure 6 shows both sets of apparatus.

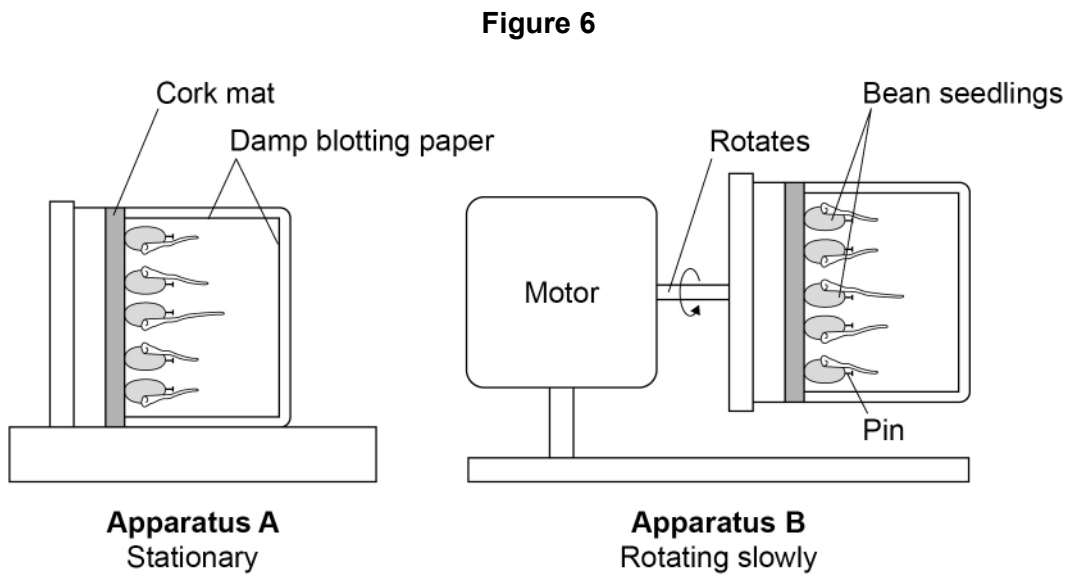

The student left both sets of apparatus in a dark cupboard for 24 hours.



0 4 . 1 Give the reason why the student placed both sets of apparatus in the dark.

[1 mark]

0 4 . 2 What are **two** reasons for surrounding the seedlings with damp blotting paper?

[2 marks]

Tick (✓) **two** boxes.

To prevent photosynthesis in the roots

To prevent the growth of mould on the roots

To prevent water affecting the direction of root growth

To provide enough water for root growth

To provide the roots with mineral ions

0 4 . 3 Apparatus **B** is a control.

Explain why apparatus **B** is needed.

[2 marks]

Question 4 continues on the next page

Turn over ►



0 4 . 4

Figure 7 shows one seedling from apparatus **A** at the start of the investigation and after 24 hours.

The drawing of the seedling after 24 hours is **not** complete.

Figure 7

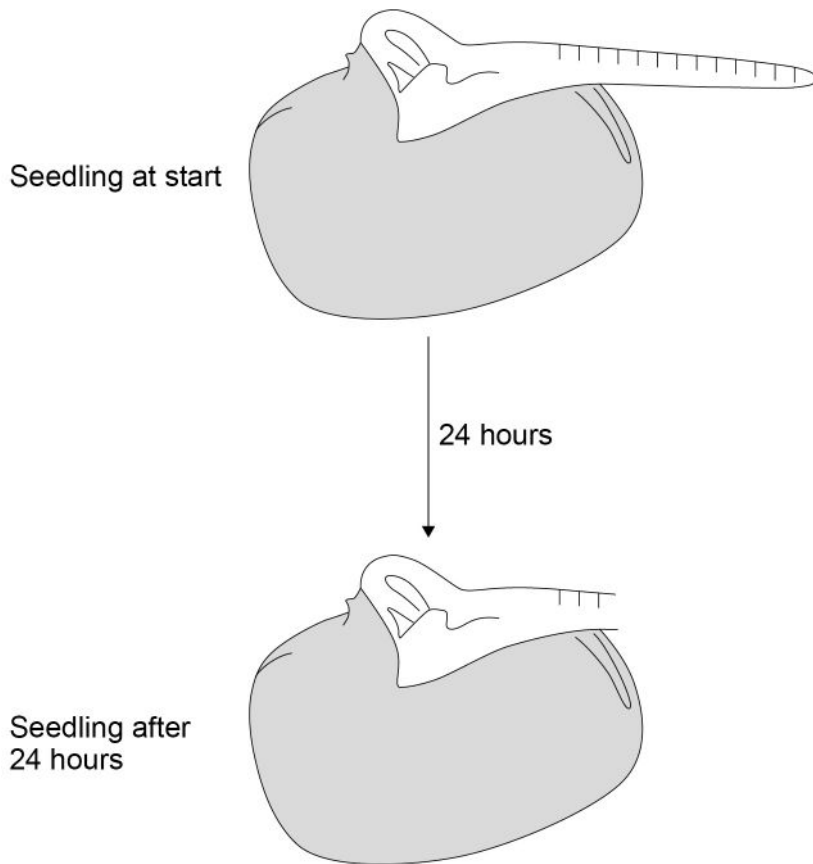

Complete **Figure 7** to show:

- the appearance of the root after 24 hours
- the ink marks on the root after 24 hours.

[3 marks]



Figure 6 is repeated below.

Figure 6

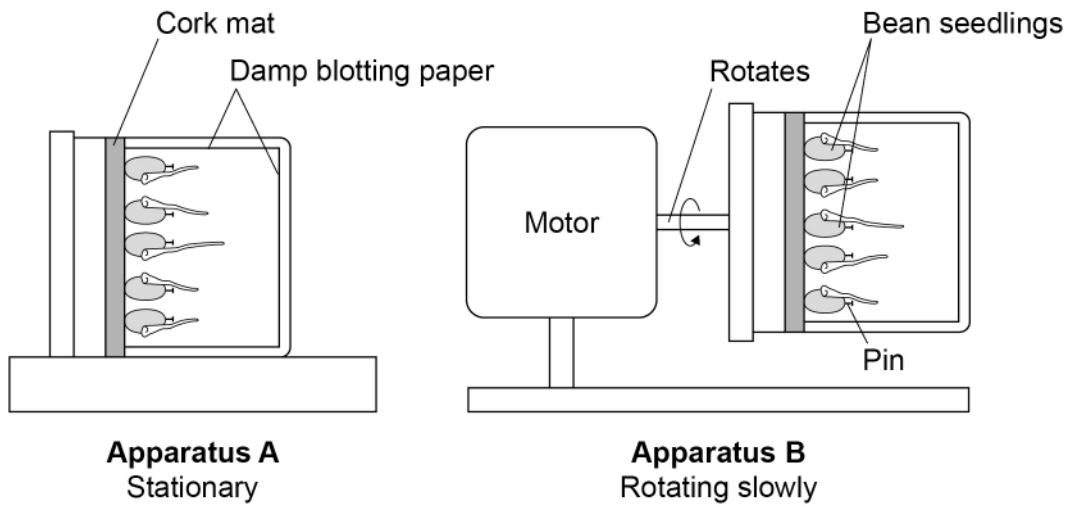

The student left both sets of apparatus in a dark cupboard for 24 hours.

0 4 . 5

Describe how a root from apparatus **B** would look different from the root you drew in Question **04.4**.

[1 mark]

0 4 . 6

Auxin is a plant hormone.

Explain how auxin causes the results in apparatus **A**.

[2 marks]

Question 4 continues on the next page

Turn over ►



Farmers can use plant hormones to control the growth of plants.

0 4 . 7 Give **two** uses of auxin.

[2 marks]

1 _____

2 _____

0 4 . 8 A farmer sprayed an apple tree with gibberellin.

Suggest **two** reasons why the farmer sprayed the apple tree with gibberellin.

[2 marks]

1 _____

2 _____

15



Turn over for the next question

*Do not write
outside the
box*

**DO NOT WRITE ON THIS PAGE
ANSWER IN THE SPACES PROVIDED**

Turn over ►



0 5

The human body has two coordination systems:

- the nervous system
- the endocrine system.

0 5 . 1

Two students investigated human reaction time.

Student **A** held a metre rule above student **B**'s hand.

Student **A** then released the metre rule and student **B** caught the rule as quickly as possible.

Figure 8 shows the method used.

Figure 8

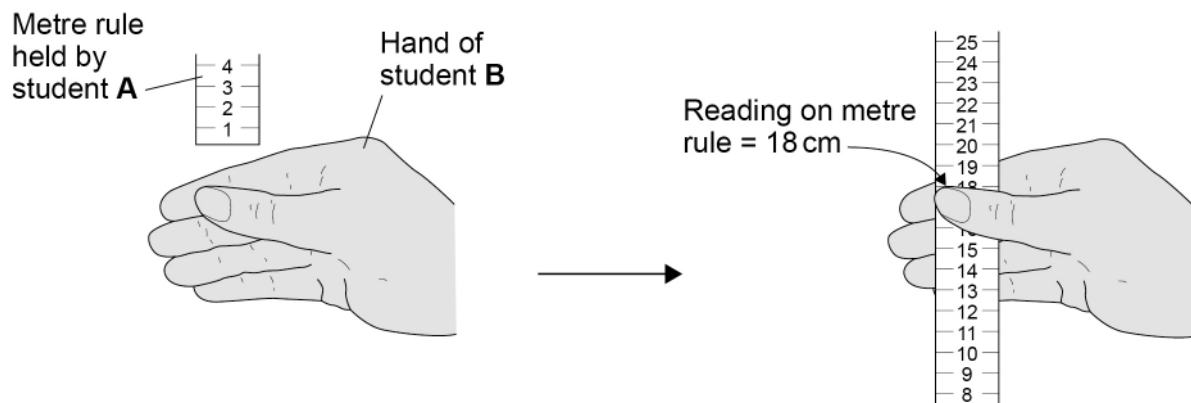

Suggest **two** ways to improve the students' method for measuring human reaction time.

[2 marks]

1 _____

2 _____



0 5 . 2Student **B**'s reaction is coordinated by the nervous system.Give **two** ways that coordination by the endocrine system is different from coordination by the nervous system.**[2 marks]**

1 _____

2 _____

Question 5 continues on the next page**Turn over ►**

Figure 9 shows endocrine glands in a female.

Figure 9

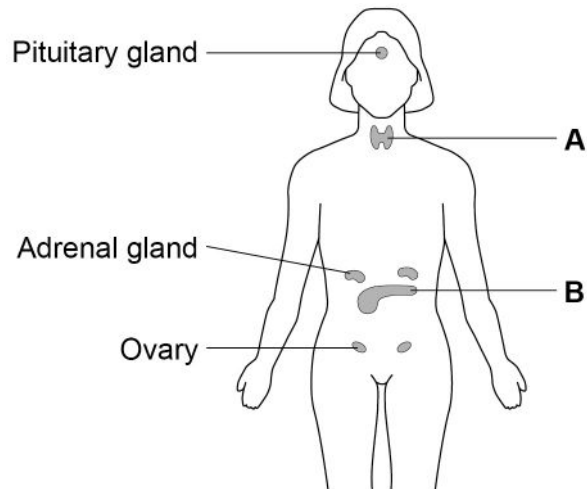

0 5 . 3 Name **one** hormone produced by gland **A**.

[1 mark]

0 5 . 4 Name **one** hormone produced by gland **B**.

[1 mark]

0 5 . 5 The adrenal gland produces the hormone adrenaline.

Describe **two** effects of adrenaline on the human body.

[2 marks]

1 _____

2 _____



0 6

Some human disorders are inherited.

Polydactyly is an inherited disorder.

- A person with polydactyly has extra fingers or toes.
- Polydactyly is caused by a dominant allele.

0 6 . 1

What is a dominant allele?

[1 mark]

Figure 10 shows the inheritance of polydactyly in one family.

Figure 10

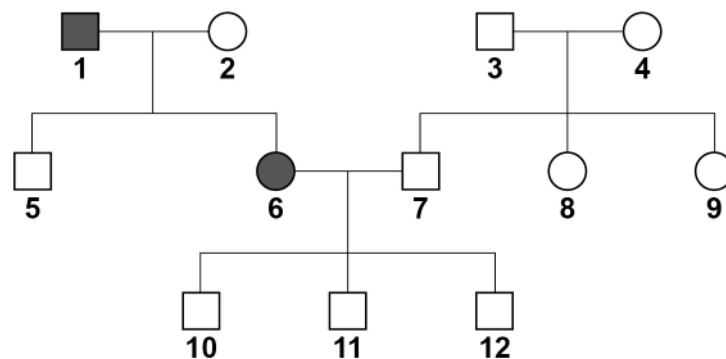

Key

- Male who has polydactyly
- Male who does **not** have polydactyly
- Female who has polydactyly
- Female who does **not** have polydactyly



In questions **06.2** and **06.3**, use the following symbols:

D = allele for having polydactyly

d = allele for **not** having polydactyly.

06.2 Person **1** is heterozygous.

Explain how **Figure 10** shows that person **1** is heterozygous.

[2 marks]

06.3 Persons **6** and **7** are expecting a fourth child.

A doctor states that the probability of having a child with polydactyly is 0.5

Explain how the doctor determined this probability.

[4 marks]

You should:

- draw a Punnett square diagram
- give the genotype of person **6** and the genotype of person **7**
- identify **all** the offspring that will have polydactyly.

Question 6 continues on the next page

Turn over ►



0 6 . 4

Cystic fibrosis (CF) is another inherited disorder caused by a mutation.

The mutation occurs in a gene called CFTR.

For the CFTR gene, one **allele** in every 50 in the UK population is the cystic fibrosis allele.

Explain why only one person in 2500 in the UK population has cystic fibrosis.

[4 marks]

11



0 7 . 2 Another farmer produced 4200 kg of maize seeds in a field.

The farmer fed the maize to 1000 chickens.

At full size, the mean mass of one chicken was 2.2 kg.

Complete **Figure 11** to show a pyramid of biomass for the food chain from the maize seeds to 1000 chickens.

[3 marks]

You should:

- label the x-axis
- use a suitable scale.

Figure 11

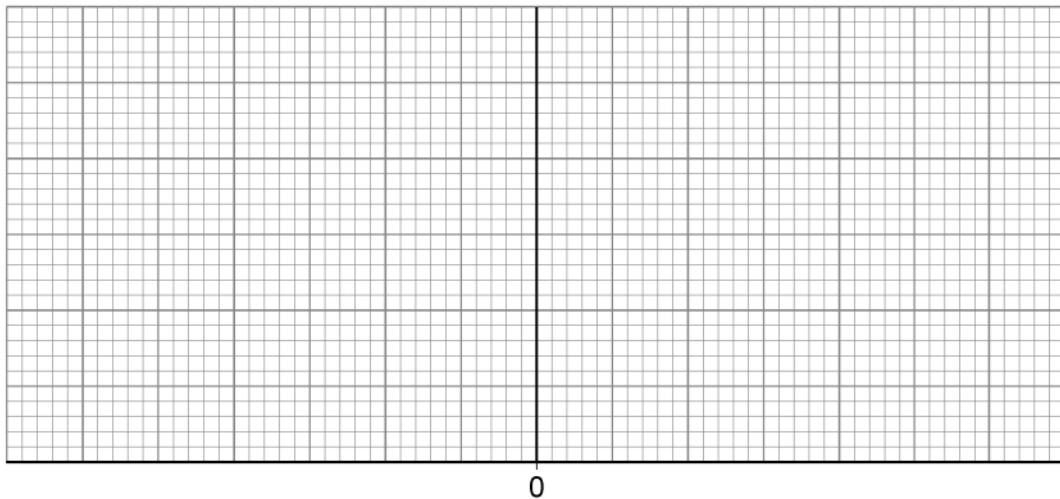

0 7 . 3 Calculate the ratio of chicken biomass to maize seed biomass.

Use data from Question **07.2**.

Give your answer in its simplest form.

[2 marks]

Ratio = _____ : _____

0 7 . 4 Chickens can use 80% of the biomass from the maize seeds they eat for respiration and growth.

What happens to the remaining 20% of the biomass in the maize seeds?

[1 mark]

Question 7 continues on the next page

Turn over ►



Protein is an important part of a chicken's diet.

- Proteins contain 20 different types of amino acid.
- A chicken can make many of the 20 amino acids from other substances in the diet.
- Essential amino acids are amino acids the chicken **cannot** make.
- Essential amino acids must be included in the diet.

Maize seeds contain protein but the proportion of some essential amino acids is low.

Scientists have produced a type of maize called Quality Protein Maize (QPM).

Table 2 compares the proportions of seven essential amino acids in normal maize seeds and in QPM seeds.

Table 2

Amino acid	Mass of amino acid in protein in g/kg	
	Normal maize	Quality protein maize (QPM)
Leucine	122.2	88.1
Lysine	28.9	41.9
Methionine	19.9	18.1
Phenylalanine	49.4	40.9
Threonine	34.5	36.5
Tryptophan	7.3	16.3
Valine	45.9	51.2



0 7 . 5 Which amino acids are found in significantly higher proportions in the QPM seeds?

[1 mark]

Tick (✓) **one** box.

Lysine and tryptophan

Lysine and valine

Threonine and tryptophan

Threonine and valine

0 7 . 6 **Table 2** shows that 1 kg of QPM contains less leucine than 1 kg of normal maize.

Suggest why a diet containing less leucine does **not** slow down the growth of chickens.

[1 mark]

13

Turn over for the next question

Turn over ►



0 8

Conditions inside and outside of the human body often change.

Homeostasis helps the human body to survive changing conditions.

0 8 . 1

Explain what is meant by the term 'homeostasis'.

[2 marks]

The kidneys have an important role in homeostasis.

0 8 . 2

Describe what happens to **glucose**, **protein** and **urea** in the kidneys.

[4 marks]



0 8 . 3

Explain how ADH affects the production and concentration of urine by the kidneys.

[4 marks]

10

Turn over for the next question

Turn over ►



0 9 . 2

Suggest **two** reasons why some people are concerned about the use of GM soya bean plants.

Do **not** refer to ethical concerns or religion in your answer.

[2 marks]

1 _____

2 _____

8

END OF QUESTIONS



There are no questions printed on this page

*Do not write
outside the
box*

**DO NOT WRITE ON THIS PAGE
ANSWER IN THE SPACES PROVIDED**



There are no questions printed on this page

*Do not write
outside the
box*

**DO NOT WRITE ON THIS PAGE
ANSWER IN THE SPACES PROVIDED**

Copyright information

For confidentiality purposes, all acknowledgements of third-party copyright material are published in a separate booklet. This booklet is published after each live examination series and is available for free download from www.aqa.org.uk.

Permission to reproduce all copyright material has been applied for. In some cases, efforts to contact copyright-holders may have been unsuccessful and AQA will be happy to rectify any omissions of acknowledgements. If you have any queries please contact the Copyright Team.

Copyright © 2024 AQA and its licensors. All rights reserved.

